

FFASTS28-000441BT0

250

DuoSTiX™ Hygiene Spray_Matte Black

STYLE SEGMENT

- Modern

KEY SPECIFICATIONS

- Product Dimensions: 252x112x81
- Material: Plastic
- Color Availability: Contact us for more information
- Flow Rate: 5.06
- Additional Components Included: Contact us for more information
- Hose Included: Yes

SHIPPING WEIGHT

- Net Weight: Contact us for more information
- Gross Weight: Contact us for more information

KEY TECHNOLOGIES AND FEATURES

HYGIENE

- Jet Spray

COMFORT

- Petal Pressure

CONVENIENCE

- EasyClean

DURABILITY

- Complies with American Standard Quality Standards

SUSTAINABILITY

- Complies with American Standard Quality Standards

SAFETY

- Complies with American Standard Quality Standards

OTHERS

- NIL

STANDARDS AND CERTIFICATIONS

- GB/T 23447-2009
- GB/T 23448-2019



FFASTS28-000441BT0

250

DuoSTiX™ Hygiene Spray_Matte Black

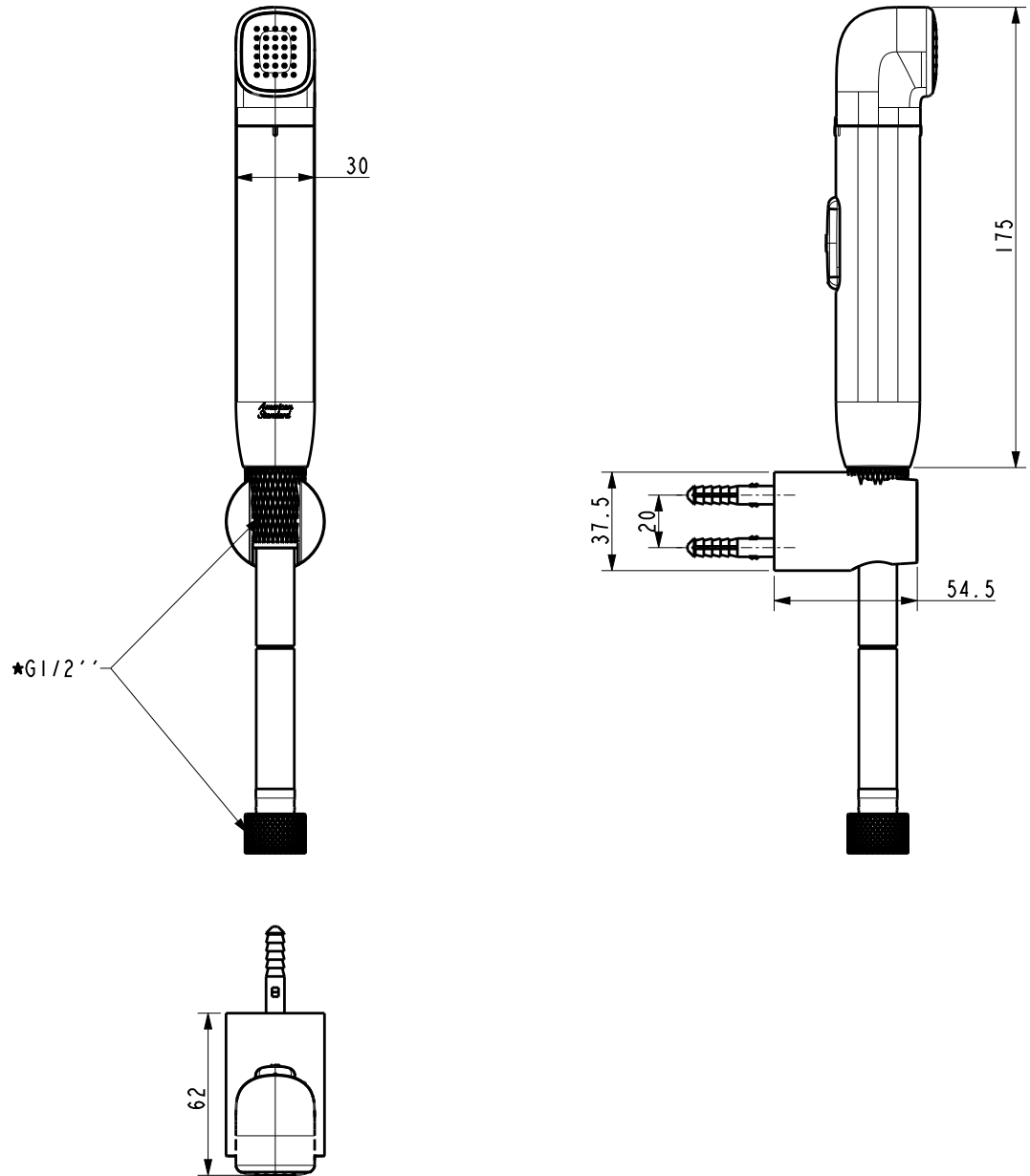

FFASTS28-000441BT0

250

DuoSTiX™ Hygiene Spray_Matte Black

Components	Description	Contact us for more information
	Weight (kg)	0.35
	Dimensions (mm)	252x112x81
	Material	Plastic
	Flow Rate	5.06
Shipping	Additional Components Included	Contact us for more information
	Hose Included	Yes